

**STRATA PLAN OF PART OF LOT 3 SECTION 31
TOWNSHIP 26 OSOYOOS DIVISION YALE
DISTRICT PLAN EPP100150**

SHEET 1 OF 22 SHEETS

**STRATA PLAN EPS9966
PHASE 1**

BCGS 82E.083



The intended plot size of this plan is 432mm in width by 280mm in height (B size) when plotted at a scale of 1:600
(All distances are in metres)

1455 Cara Glen Court,
Kelowna, B.C.

LEGEND

- Denotes Standard Iron post (Type 5) found
- Denotes Standard Iron post (Type 5) placed
- ⊙ Denotes Control Monument found
- Reset Denotes IP previously tied February 6, 2020 (See Plan EPP100150) lost and replaced using ties from the original control traverse.

73H1793
UTM Zone 11 coordinates
Datum: NAD83(CSRS) 4.0.0.BC.1
UTM northing: 5531148.644
UTM easting: 323074.222
Estimated Absolute Accuracy
Achieved: 0.02m.

74H2435
UTM Zone 11 coordinates
Datum: NAD83(CSRS) 4.0.0.BC.1
UTM northing: 5530188.896
UTM easting: 323085.815
Estimated Absolute Accuracy
Achieved: 0.02m.

Integrated Survey Area No. 4, City of Kelowna,
NAD83 (CSRS) 4.0.0.BC.1

Grid bearings are derived from GNSS observations and are referred to the central meridian of UTM Zone 11.

The UTM coordinates and estimated absolute accuracies achieved are derived from survey ties to geodetic control monuments 73H1793 and 74H2435.

This plan shows horizontal ground-level distances unless otherwise specified. To compute grid distances, multiply ground-level distances by the combined factor of 0.9999168 which has been derived from geodetic control monument 73H1793.

Measurements to exterior foundation on this sheet.

Offsets to property lines are perpendicular thereto and are measured to the exterior face of building foundation wall.

This Plan is Phase 1 of a 3 phase strata plan under section 224 of the Strata Property Act lying within the jurisdiction of the Approving Officer for the City of Kelowna.

RUNNALLS DENBY

british columbia land surveyors

259A Lawrence Avenue
Kelowna, B.C.
V1Y 6L2

Phone: (250)763-7322
Email: jen@runnallsdenby.com

DWG. No.: 16488 Strata Ph 1

FILE: 16488

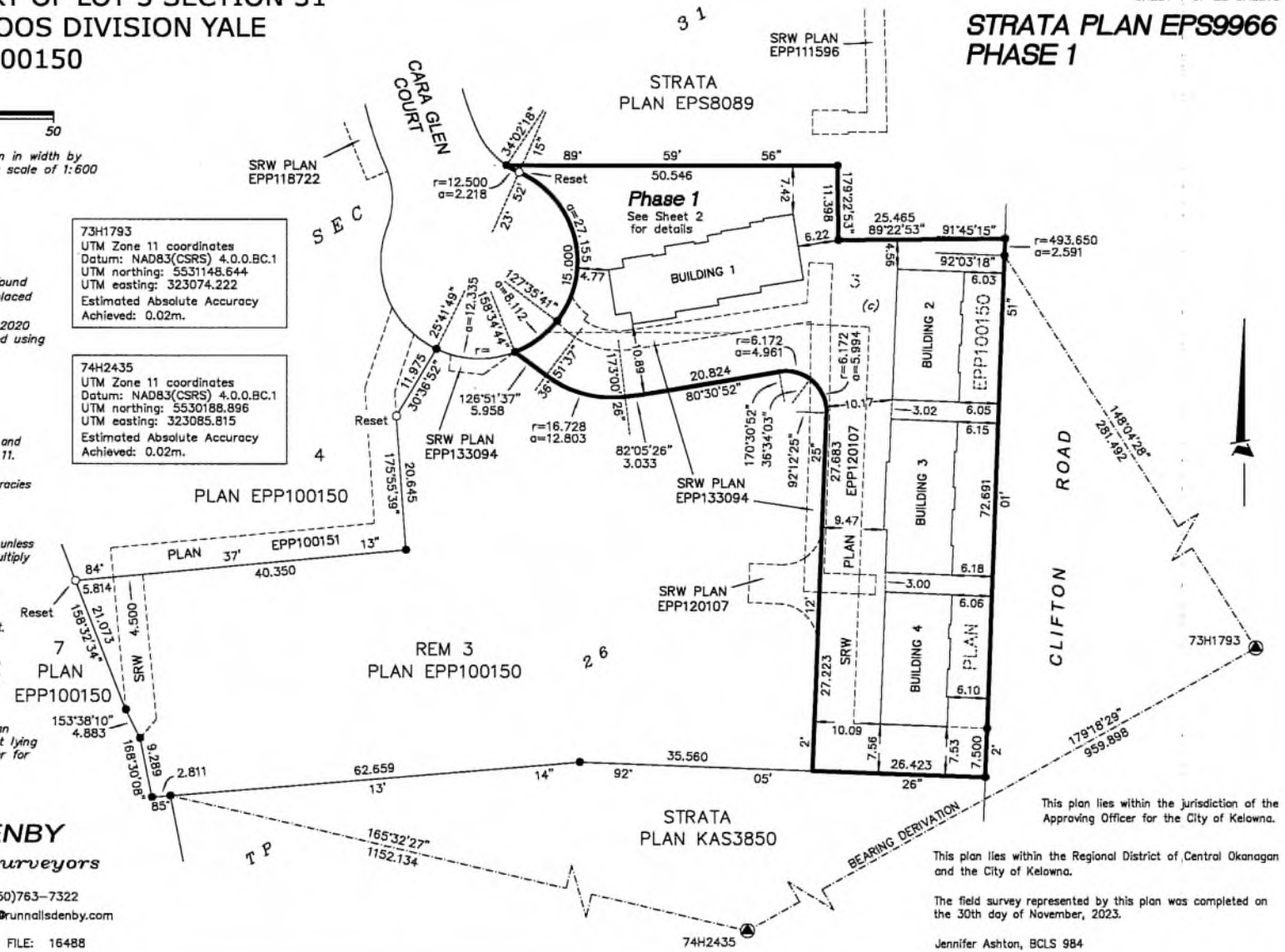

BUILDING 1 LEVEL 1

Sheet 3 of 22 Sheets

STRATA PLAN EPS9966 PHASE 1



The intended plot size of this plan is 432mm in width by 280mm in height (B size) when plotted at a scale of 1:150
(All distances are in metres)

LEGEND

- SL Denotes Strata Lot
- (c) Denotes Common Property
- LCP Denotes Limited Common Property
- PT Denotes Part of Strata Lot
- NH Denotes Non-Habitable
- MECH Denotes Mechanical Room

This sheet shows strata boundary dimensions to the midpoint of the structural portion of the exterior walls and the midpoint between structural portions of party walls between strata lots.

Gross section arrows on this plan point in the direction of view.

All LCP Patios, Decks, Driveways and Terraces are limited in height by the center of the floor above, or its extensions, or where there is no floor above, by the average height of a Strata Lot in the same building, unless otherwise indicated.

This sheet does not include any grid bearings, non-tangential deflections are noted as angles in degrees and minutes.

Strata lot boundary midpoint of structural portion of party wall between strata lots (typ)

LCP boundary midpoint of structural portion of exterior wall (typ)

Strata lot boundary midpoint of structural portion of exterior walls (typ)

SRW PLAN
EPP133094

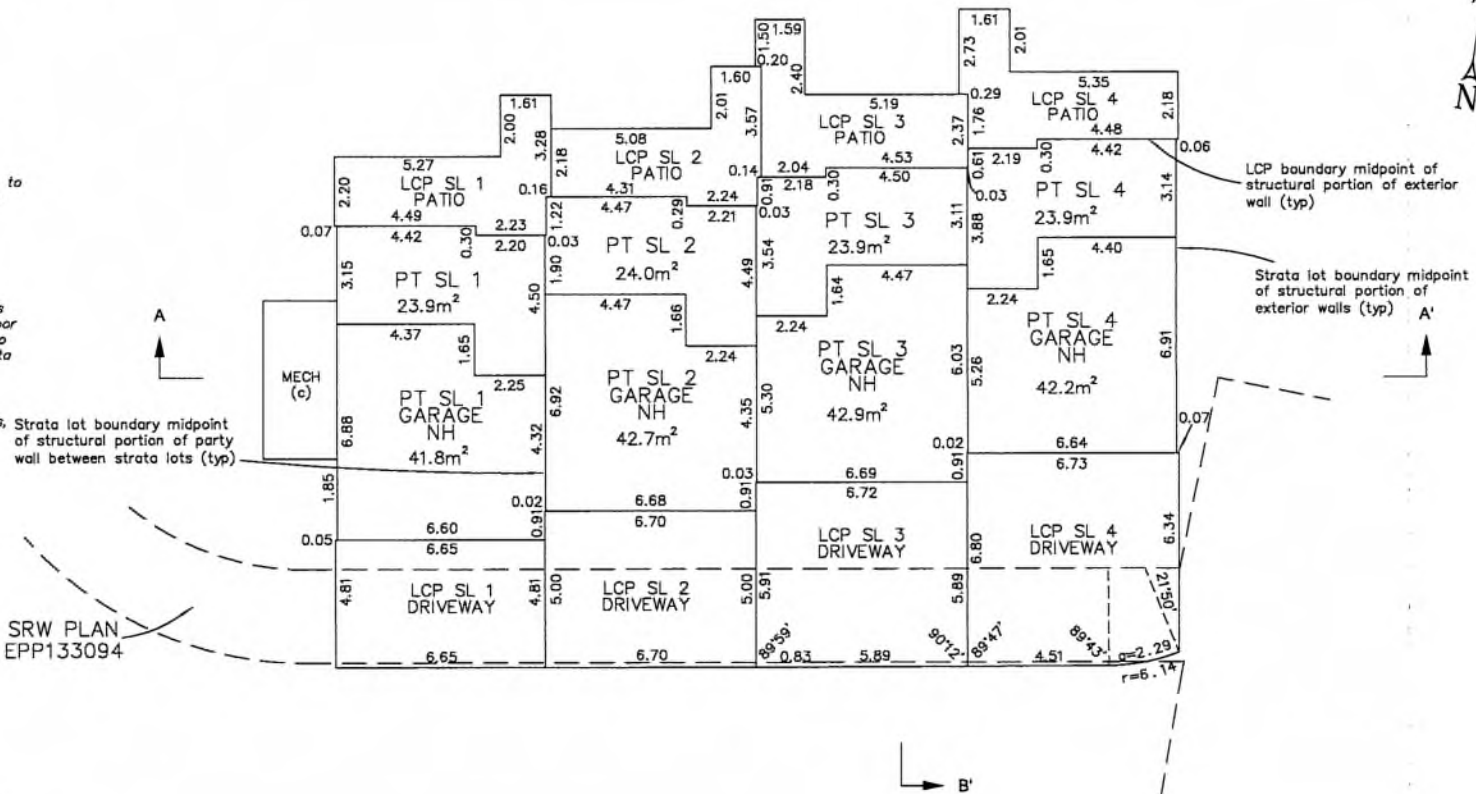

RUNNALLS DENBY

british columbia land surveyors

259A Lawrence Avenue
Kelowna, B.C.
V1Y 6L2

Phone: (250)763-7322
Email: jen@runnallsdenby.com

DWG. No.: 16488 Strata

FILE: 16488

Jennifer Ashton, BCLS 984
November 30, 2023

BUILDING 1 LEVEL 2

STRATA PLAN EPS9966 PHASE 1



The intended plot size of this plan is 432mm in width by 280mm in height (B size) when plotted at a scale of 1:150

(All distances are in metres)

LEGEND

- SL Denotes Strata Lot
- (c) Denotes Common Property
- LCP Denotes Limited Common Property
- PT Denotes Part of Strata Lot
- PFB Denotes Perimeter of Floor Below

This sheet shows strata boundary dimensions to the midpoint of the structural portion of the exterior walls and the midpoint between structural portions of party walls between strata lots.

Cross section arrows on this plan point in the direction of view.

All LCP Patios, Decks, Driveways and Terraces are limited in height by the center of the floor above, or its extensions, or where there is no floor above, by the average height of a Strata Lot in the same building, unless otherwise indicated.

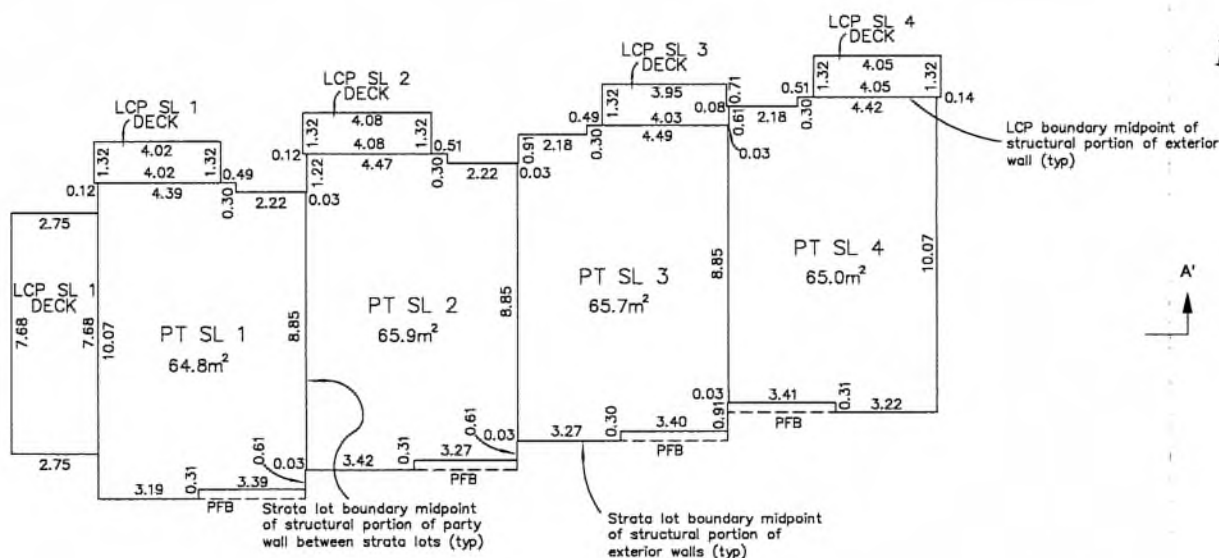

RUNNALLS DENBY

british columbia land surveyors

259A Lawrence Avenue
Kelowna, B.C.
V1Y 6L2

Phone: (250)763-7322
Email: jen@runnallsdenby.com

BUILDING 1 LEVEL 3

STRATA PLAN EPS9966 PHASE 1



The intended plot size of this plan is 432mm in width by 280mm in height (B size) when plotted at a scale of 1:150
(All distances are in metres)

LEGEND

- SL Denotes Strata Lot
- (c) Denotes Common Property
- LCP Denotes Limited Common Property
- PT Denotes Part of Strata Lot

This sheet shows strata boundary dimensions to the midpoint of the structural portion of the exterior walls and the midpoint between structural portions of party walls between strata lots.

Cross section arrows on this plan point in the direction of view.

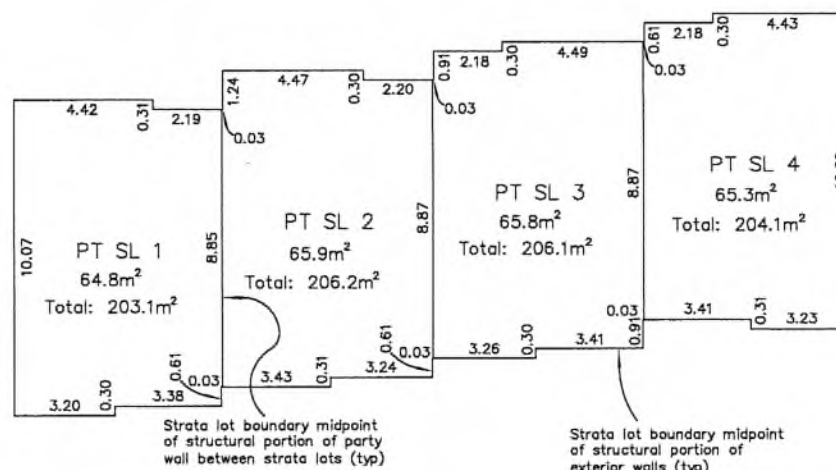

RUNNALLS DENBY

british columbia land surveyors

259A Lawrence Avenue
Kelowna, B.C.
V1Y 6L2

Phone: (250)763-7322
Email: jen@runnallsdenby.com

BUILDING 1 CROSS SECTION

STRATA PLAN EPS9966 PHASE 1



The intended plot size of this plan is 432mm in width by 280mm in height (B size) when plotted at a scale of 1:150
(All distances are in metres)

LEGEND

- SL Denotes Strata Lot
- (c) Denotes Common Property
- LCP Denotes Limited Common Property
- PT Denotes Part of Strata Lot
- NH Denotes Non-Habitable

This sheet shows strata boundary dimensions to the midpoint of the structural portion of the exterior walls and the midpoint between structural portions of party walls between strata lots.

CROSS SECTION A-A'

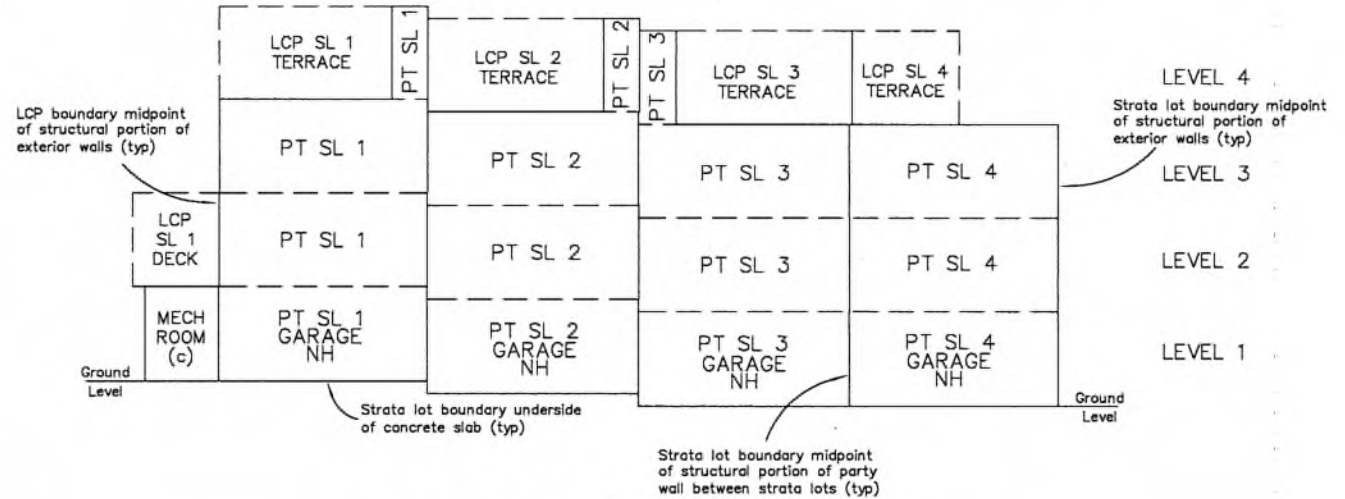

CROSS SECTION B-B'

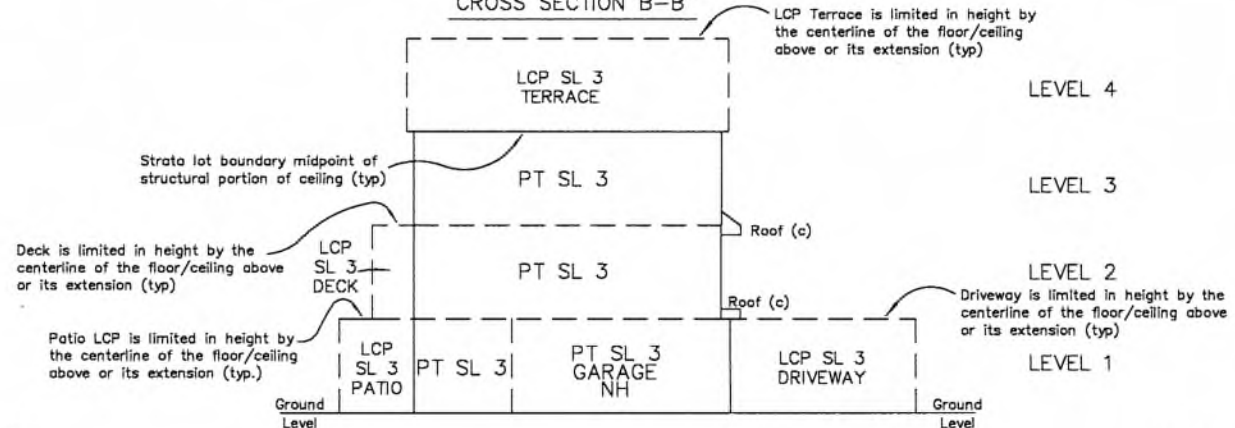

RUNNALLS DENBY
british columbia land surveyors

259A Lawrence Avenue
Kelowna, B.C.
V1Y 6L2

Phone: (250)763-7322
Email: jen@runnallsdenby.com

DWG. No.: 16488 Strata

FILE: 16488

Jennifer Ashton, BCLS 984
November 30, 2023

BUILDING 2 LEVEL 1

STRATA PLAN EPS9966 PHASE 1



The intended plot size of this plan is 432mm in width by 280mm in height (B size) when plotted at a scale of 1:125
(All distances are in metres)

LEGEND

- SL Denotes Strata Lot
- NH Denotes Non-Habitable
- LCP Denotes Limited Common Property
- PT Denotes Part of Strata Lot

This sheet shows strata boundary dimensions to the midpoint of the structural portion of the exterior walls and the midpoint between structural portions of party walls between strata lots.

All LCP Patios, Decks, Driveways and Terraces are limited in height by the center of the floor above, or its extensions, or where there is no floor above, by the average height of a Strata Lot in the same building, unless otherwise indicated.

Cross section arrows on this plan point in the direction of view.

This sheet does not include any grid bearings, non-tangential deflections are noted as angles in degrees and minutes.

Strata lot boundary midpoint of structural portion of party wall between strata lots (typ)

LCP boundary midpoint of structural portion of exterior wall (typ)

Strata lot boundary midpoint of structural portion of exterior walls (typ)

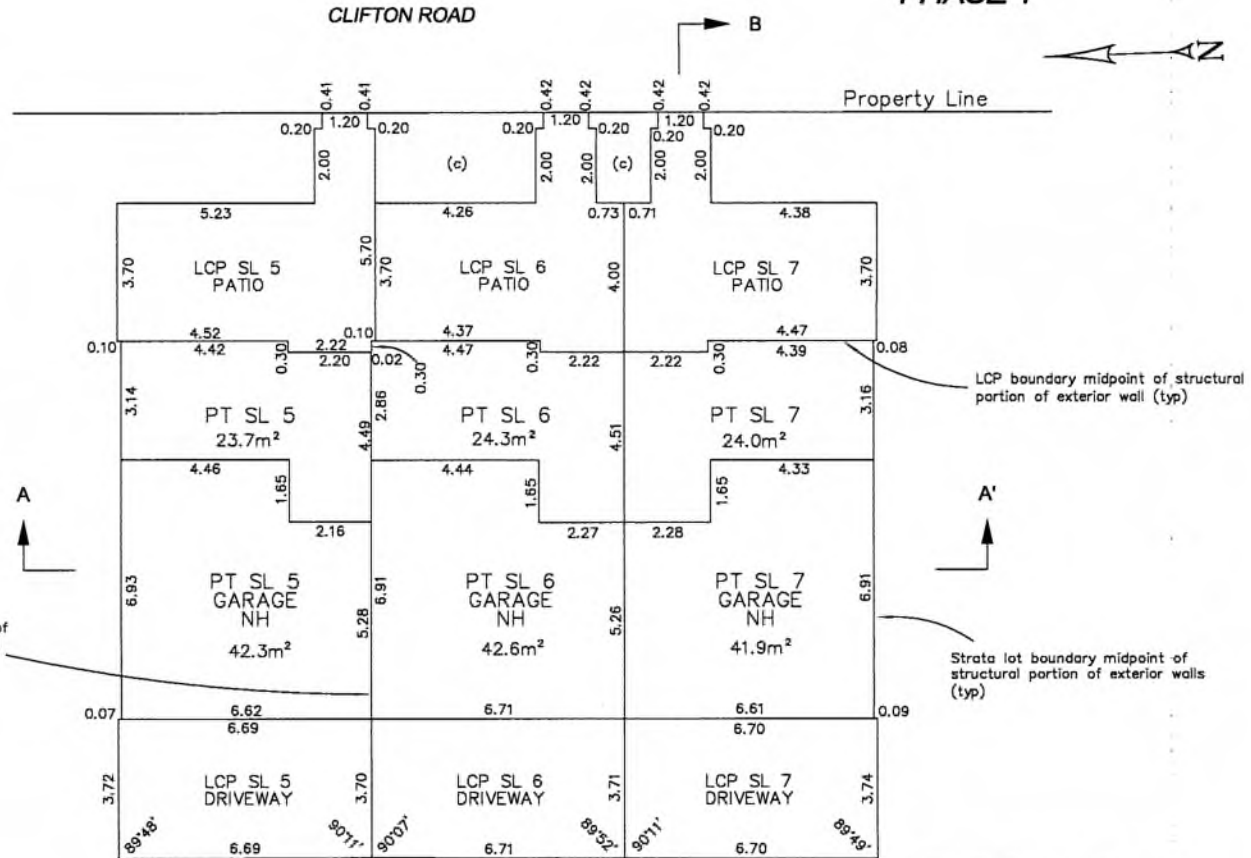

RUNNALLS DENBY

british columbia land surveyors

259A Lawrence Avenue
Kelowna, B.C.
V1Y 6L2

Phone: (250)763-7322
Email: jen@runnallsdenby.com

DWG. No.: 16488 Strata

FILE: 16488

SRW PLAN EPP120107

Jennifer Ashton, BCLS 984
November 30, 2023

BUILDING 2 LEVEL 2

Sheet 9 of 22 Sheets

STRATA PLAN EPS9966 PHASE 1



The intended plot size of this plan is 432mm in width by 290mm in height (B size) when plotted at a scale of 1:125
(All distances are in metres)

LEGEND

- SL Denotes Strata Lot
- NH Denotes Non-Habitable
- LCP Denotes Limited Common Property
- PT Denotes Part of Strata Lot
- PFB Denotes Perimeter of Floor Below

This sheet shows strata boundary dimensions to the midpoint of the structural portion of the exterior walls and the midpoint between structural portions of party walls between strata lots.

All LCP Patios, Decks, Driveways and Terraces are limited in height by the center of the floor above, or its extensions, or where there is no floor above, by the average height of a Strata Lot in the same building, unless otherwise indicated.

Cross section arrows on this plan point in the direction of view.

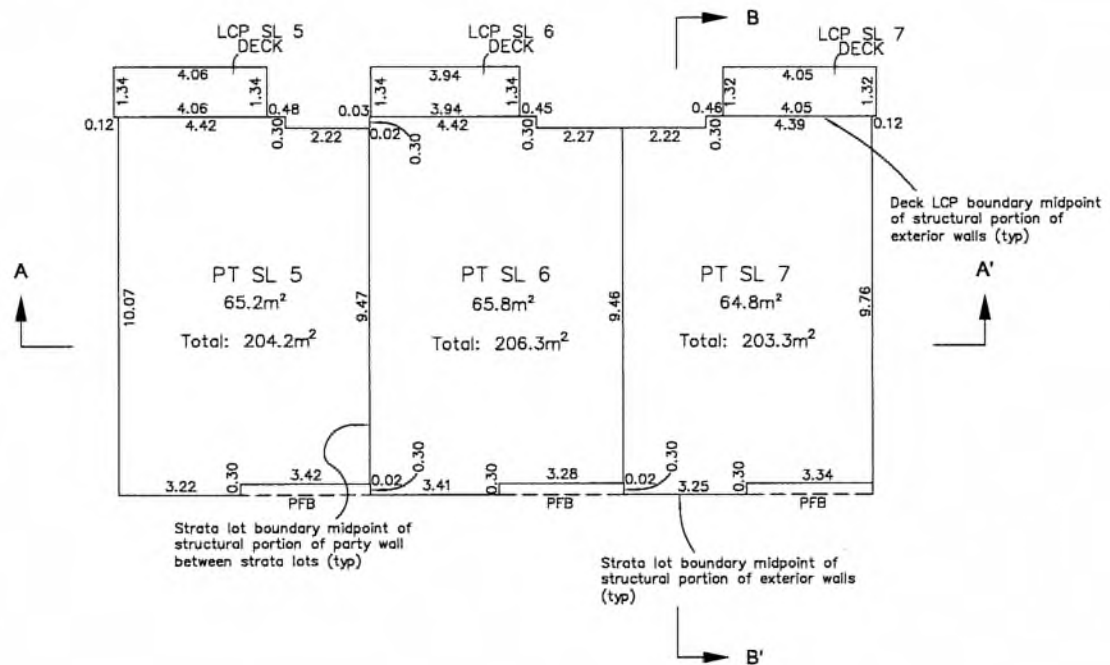

RUNNALLS DENBY

british columbia land surveyors

259A Lawrence Avenue
Kelowna, B.C.
V1Y 6L2

Phone: (250)763-7322
Email: jen@runnallsdenby.com

DWG. No.: 16488 Strata

FILE: 16488

Jennifer Ashton, BCLS 984
November 30, 2023

BUILDING 2 LEVEL 3

STRATA PLAN EPS9966 PHASE 1



The intended plot size of this plan is 432mm in width by 280mm in height (B size) when plotted at a scale of 1:125

(All distances are in metres)

LEGEND

- SL Denotes Strata Lot
- NH Denotes Non-Habitable
- LCP Denotes Limited Common Property
- PT Denotes Part of Strata Lot

This sheet shows strata boundary dimensions to the midpoint of the structural portion of the exterior walls and the midpoint between structural portions of party walls between strata lots.

Cross section arrows on this plan point in the direction of view.

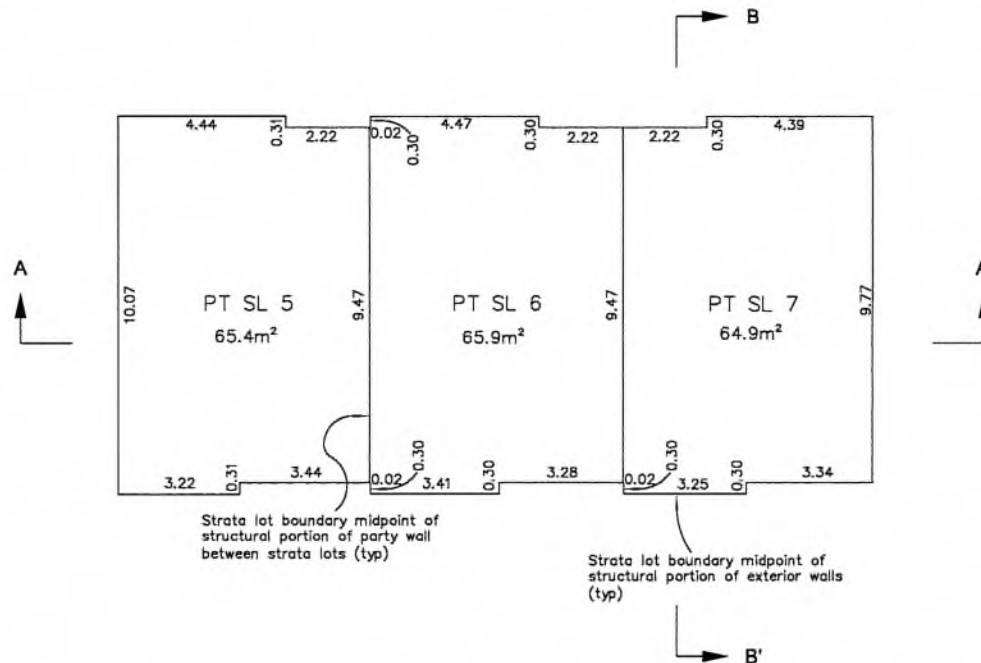

RUNNALLS DENBY

british columbia land surveyors

259A Lawrence Avenue
Kelowna, B.C.
V1Y 6L2

Phone: (250)763-7322
Email: jen@runnallsdenby.com

DWG. No.: 16488 Strata

FILE: 16488

Jennifer Ashton, BCLS 984
November 30, 2023

BUILDING 2 LEVEL 4

STRATA PLAN EPS9966 PHASE 1



The intended plot size of this plan is 432mm in width by 280mm in height (B size) when plotted at a scale of 1:125
(All distances are in metres)

LEGEND

- SL Denotes Strata Lot
- NH Denotes Non-Habitable
- LCP Denotes Limited Common Property
- PT Denotes Part of Strata Lot
- PFB Denotes Perimeter of Floor Below

This sheet shows strata boundary dimensions to the midpoint of the structural portion of the exterior walls and the midpoint between structural portions of party walls between strata lots.

All LCP Patios, Decks, Driveways and Terraces are limited in height by the center of the floor above, or its extensions, or where there is no floor above, by the average height of a Strata Lot in the same building, unless otherwise indicated.

Cross section arrows on this plan point in the direction of view.

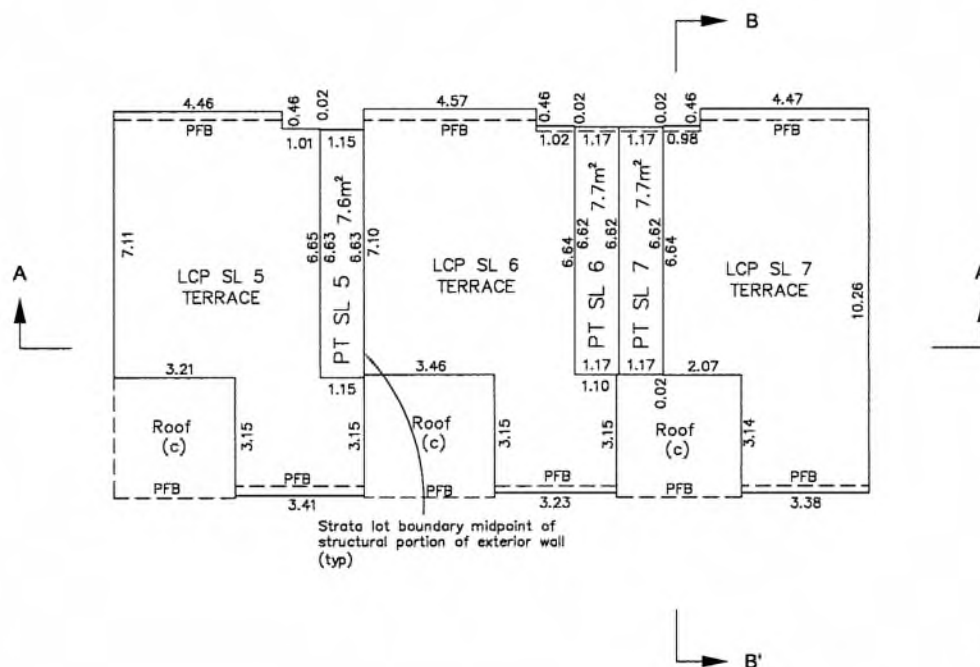

Strata lot boundary midpoint of structural portion of exterior wall (typ)

RUNNALLS DENBY

british columbia land surveyors

259A Lawrence Avenue Kelowna, B.C. V1Y 6L2
Phone: (250)763-7322 Email: jen@runnallsdenby.com

DWG. No.: 16488 Strata FILE: 16488

Jennifer Ashton, BCLS 984
November 30, 2023

BUILDING 2 CROSS SECTION

STRATA PLAN EPS9966 PHASE 1



The intended plot size of this plan is 432mm in width by 280mm in height (B size) when plotted at a scale of 1:150
(All distances are in metres)

LEGEND

- SL Denotes Strata Lot
- LCP Denotes Limited Common Property
- PT Denotes Part of Strata Lot
- NH Denotes Non-Habitable

This sheet shows strata boundary dimensions to the midpoint of the structural portion of the exterior walls and the midpoint between structural portions of party walls between strata lots.

CROSS SECTION A-A'

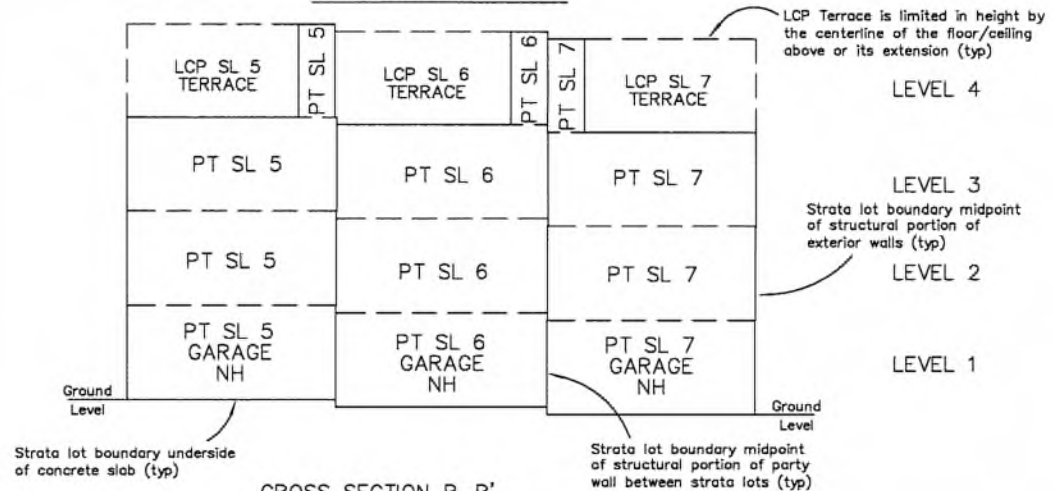

CROSS SECTION B-B'

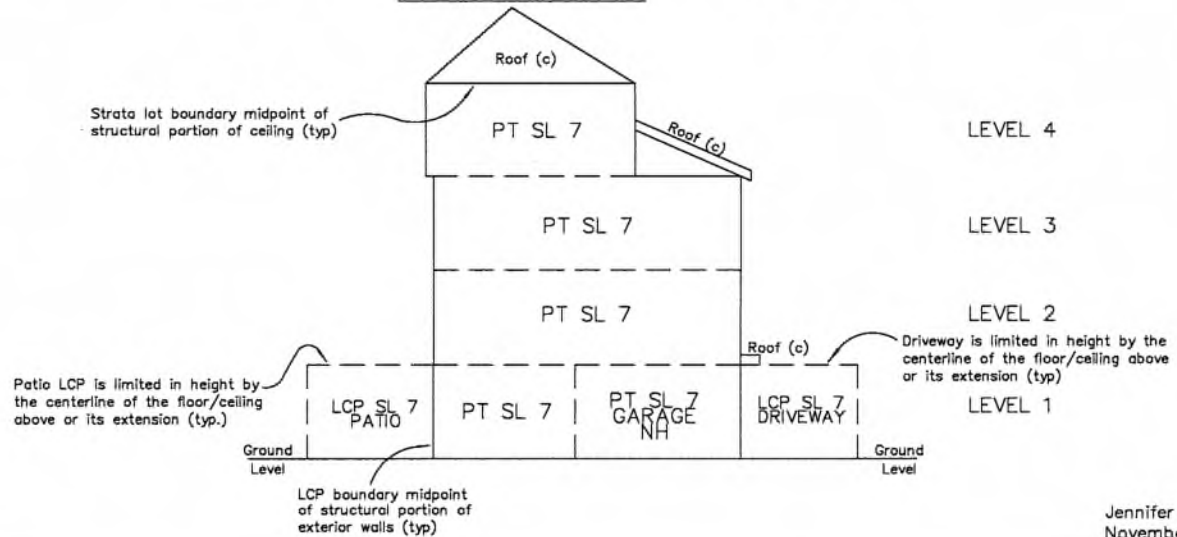

RUNNALLS DENBY
british columbia land surveyors

259A Lawrence Avenue
Kelowna, B.C.
V1Y 6L2

Phone: (250)763-7322
Email: jen@runnallsdenby.com

DWG. No.: 16488 Strata

FILE: 16488

Jennifer Ashton, BCLS 984
November 30, 2023

BUILDING 3 LEVEL 1

STRATA PLAN EPS9966 PHASE 1



The intended plot size of this plan is 432mm in width by 280mm in height (B size) when plotted at a scale of 1:150
(All distances are in metres)

LEGEND

- SL Denotes Strata Lot
- LCP Denotes Limited Common Property
- PT Denotes Part of Strata Lot
- NH Denotes Non-Habitable

This sheet shows strata boundary dimensions to the midpoint of the structural portion of the exterior walls and the midpoint between structural portions of party walls between strata lots.

Cross section arrows on this plan point in the direction of view.

All LCP Patios, Decks, Driveways and Terraces are limited in height by the center of the floor above, or its extensions, or where there is no floor above, by the average height of a Strata Lot in the same building, unless otherwise indicated.

Strata lot boundary midpoint of structural portion of exterior walls (typ)

LCP boundary midpoint of structural portion of exterior wall (typ)

Strata lot boundary midpoint of structural portion of party wall between strata lots (typ)

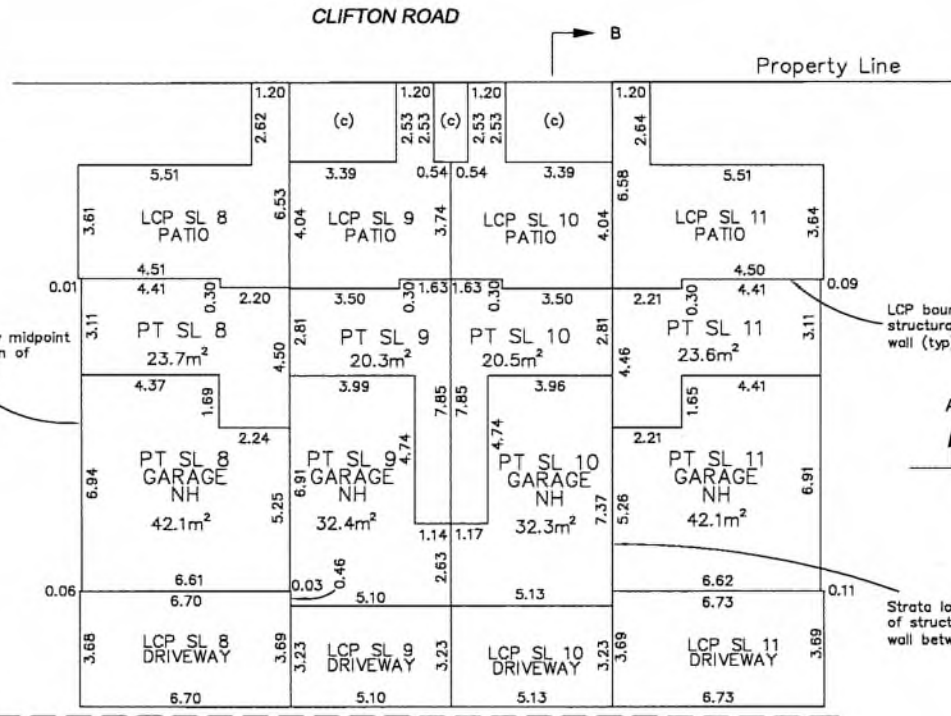

SRW PLAN EPP120107

RUNNALLS DENBY

british columbia land surveyors

259A Lawrence Avenue
Kelowna, B.C.
V1Y 6L2

Phone: (250)763-7322
Email: jen@runnallsdenby.com

BUILDING 3 LEVEL 2

Sheet 14 of 22 Sheets

STRATA PLAN EPS9966 PHASE 1



The intended plot size of this plan is 432mm in width by 280mm in height (B size) when plotted at a scale of 1:150
(All distances are in metres)

LEGEND

- SL Denotes Strata Lot
- (c) Denotes Common Property
- LCP Denotes Limited Common Property
- PT Denotes Part of Strata Lot
- PFB Denotes Perimeter of Floor Below

This sheet shows strata boundary dimensions to the midpoint of the structural portion of the exterior walls and the midpoint between structural portions of party walls between strata lots.

Cross section arrows on this plan point in the direction of view.

All LCP Patios, Decks, Driveways and Terraces are limited in height by the center of the floor above, or its extensions, or where there is no floor above, by the average height of a Strata Lot in the same building, unless otherwise indicated.

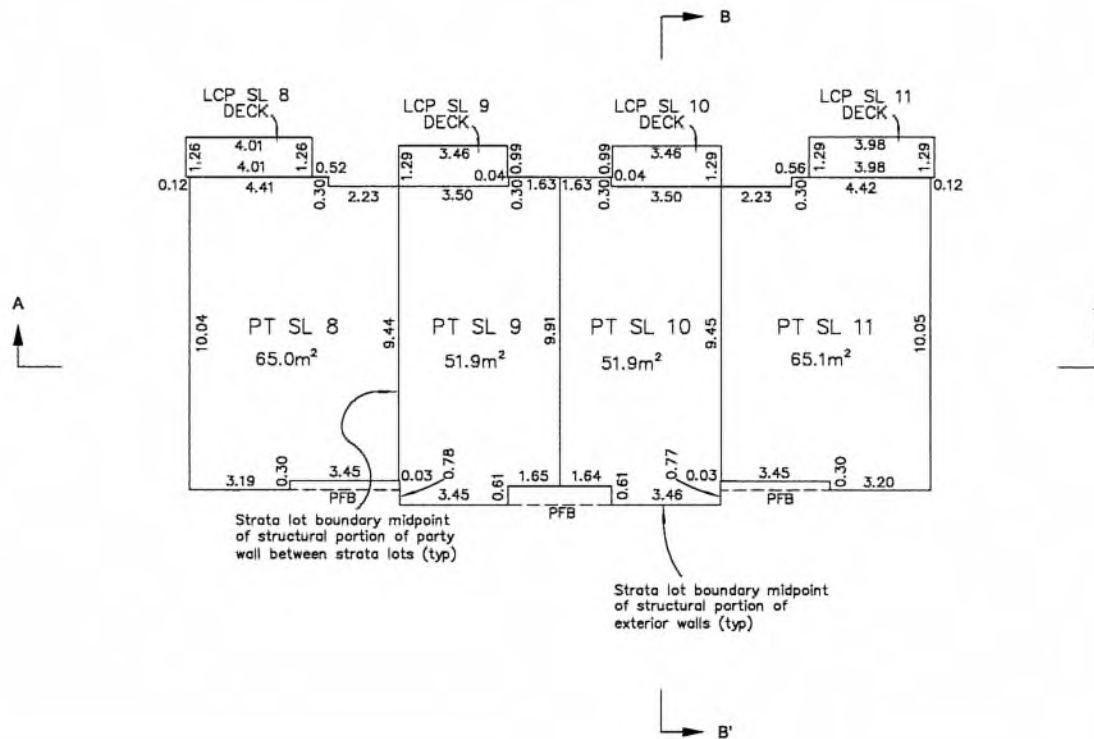

RUNNALLS DENBY

british columbia land surveyors

259A Lawrence Avenue
Kelowna, B.C.
V1Y 6L2

Phone: (250)763-7322
Email: jen@runnallsdenby.com

DWG. No.: 16488 Strata

FILE: 16488

Jennifer Ashton; BCLS 984
November 30, 2023

BUILDING 3 LEVEL 3

Sheet 15 of 22 Sheets

STRATA PLAN EPS9966 PHASE 1



The intended plot size of this plan is 432mm in width by 280mm in height (B size) when plotted at a scale of 1:150

(All distances are in metres)

LEGEND

- SL Denotes Strata Lot
- (c) Denotes Common Property
- LCP Denotes Limited Common Property
- PT Denotes Part of Strata Lot

This sheet shows strata boundary dimensions to the midpoint of the structural portion of the exterior walls and the midpoint between structural portions of party walls between strata lots.

Cross section arrows on this plan point in the direction of view.

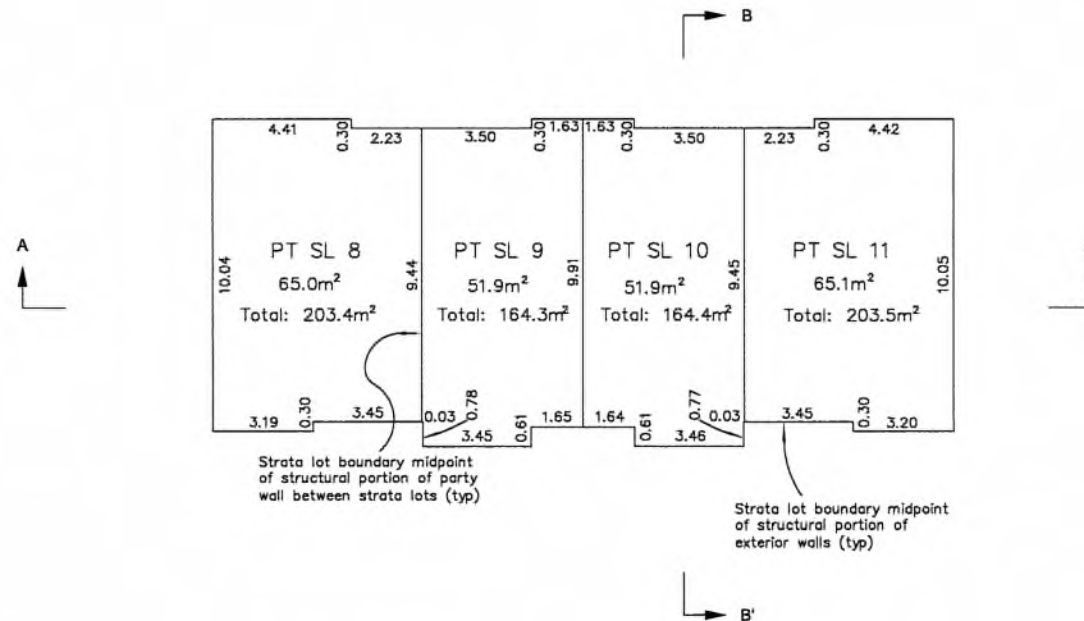

Strata lot boundary midpoint of structural portion of party wall between strata lots (typ)

Strata lot boundary midpoint of structural portion of exterior walls (typ)

RUNNALLS DENBY

british columbia land surveyors

259A Lawrence Avenue
Kelowna, B.C.
V1Y 6L2

Phone: (250)763-7322
Email: jen@runnallsdenby.com

DWG. No.: 16488 Strata

FILE: 16488

Jennifer Ashton, BCLS 984
November 30, 2023

BUILDING 3 CROSS SECTION

STRATA PLAN EPS9966 PHASE 1

CROSS SECTION A-A'



The intended plot size of this plan is 432mm in width by 280mm in height (B size) when plotted at a scale of 1:150
(All distances are in metres)

LEGEND

- SL Denotes Strata Lot
- (c) Denotes Common Property
- LCP Denotes Limited Common Property
- PT Denotes Part of Strata Lot
- NH Denotes Non-Habitable

This sheet shows strata boundary dimensions to the midpoint of the structural portion of the exterior walls and the midpoint between structural portions of party walls between strata lots.

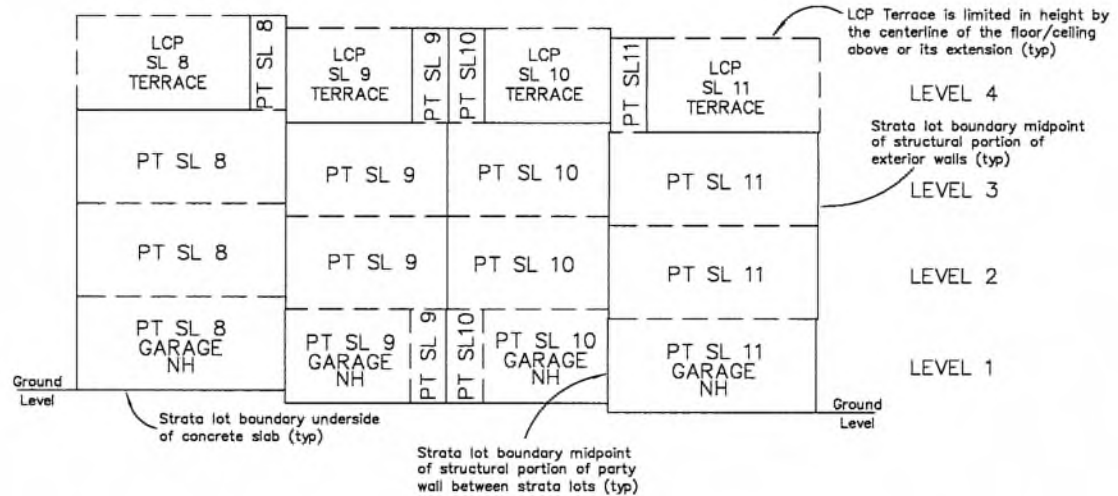

CROSS SECTION B-B'

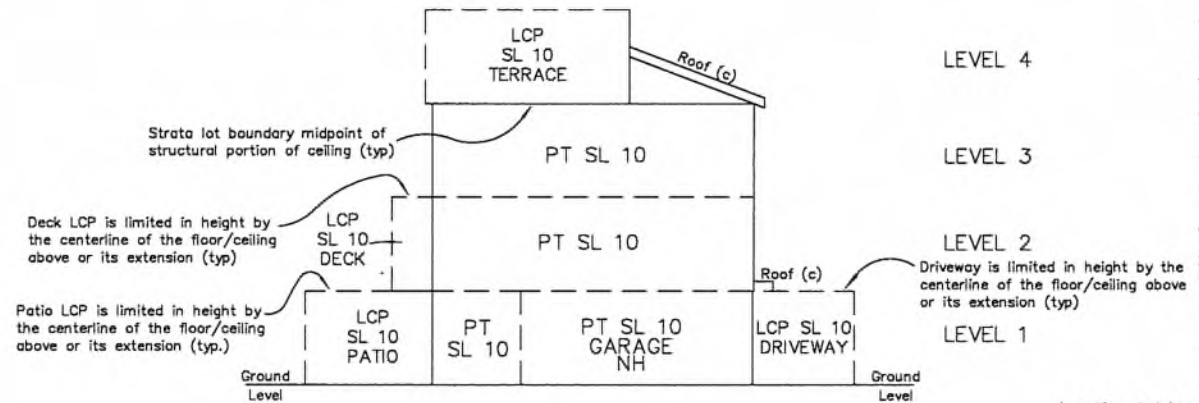

RUNNALLS DENBY
british columbia land surveyors

259A Lawrence Avenue
Kelowna, B.C.
V1Y 6L2

Phone: (250)763-7322
Email: jen@runnallsdenby.com

DWG. No.: 16488 Strata

FILE: 16488

Jennifer Ashton; BCLS 984
November 30, 2023

BUILDING 4 LEVEL 1

STRATA PLAN EPS9966 PHASE 1



The intended plot size of this plan is 432mm in width by 280mm in height (B size) when plotted at a scale of 1:125
(All distances are in metres)

LEGEND

- SL Denotes Strata Lot
- NH Denotes Non-Habitable
- LCP Denotes Limited Common Property
- PT Denotes Part of Strata Lot

This sheet shows strata boundary dimensions to the midpoint of the structural portion of the exterior walls and the midpoint between structural portions of party walls between strata lots.

All LCP walkways, decks, driveways and yards are limited in height by the centerline of the floor/ceiling above or its extension.

Gross section arrows on this plan point in the direction of view.

All LCP Patios, Decks, Driveways and Terraces are limited in height by the center of the floor above, or its extensions, or where there is no floor above, by the average height of a Strata Lot in the same building, unless otherwise indicated.

Strata lot boundary midpoint of structural portion of exterior walls (typ)

Strata lot boundary midpoint of structural portion of party wall between strata lots (typ)

LCP boundary midpoint of structural portion of exterior wall (typ)

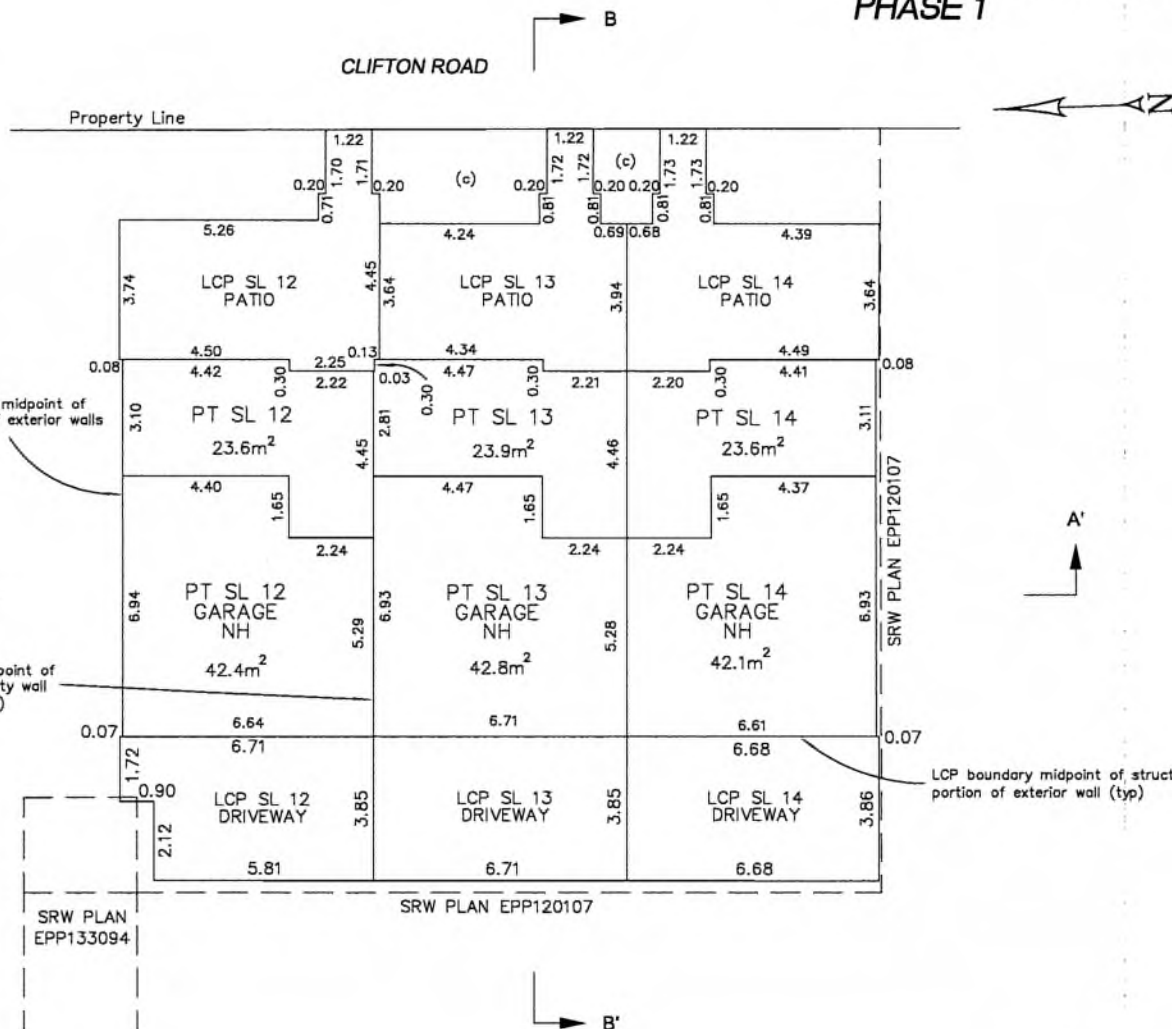

RUNNALLS DENBY

british columbia land surveyors

259A Lawrence Avenue
Kelowna, B.C.
V1Y 6L2

Phone: (250)763-7322
Email: jen@runnallsdenby.com

BUILDING 4 LEVEL 2

Sheet 19 of 22 Sheets

STRATA PLAN EPS9966 PHASE 1



The intended plot size of this plan is 432mm in width by 280mm in height (B size) when plotted at a scale of 1:125

(All distances are in metres)

LEGEND

- SL Denotes Strata Lot
- NH Denotes Non-Habitable
- LCP Denotes Limited Common Property
- PT Denotes Part of Strata Lot
- PFB Denotes Perimeter of Floor Below

This sheet shows strata boundary dimensions to the midpoint of the structural portion of the exterior walls and the midpoint between structural portions of party walls between strata lots.

All LCP walkways, decks, driveways and yards are limited in height by the centerline of the floor/ceiling above or its extension.

Cross section arrows on this plan point in the direction of view.

All LCP Patios, Decks, Driveways and Terraces are limited in height by the center of the floor above, or its extensions, or where there is no floor above, by the average height of a Strata Lot in the same building, unless otherwise indicated.

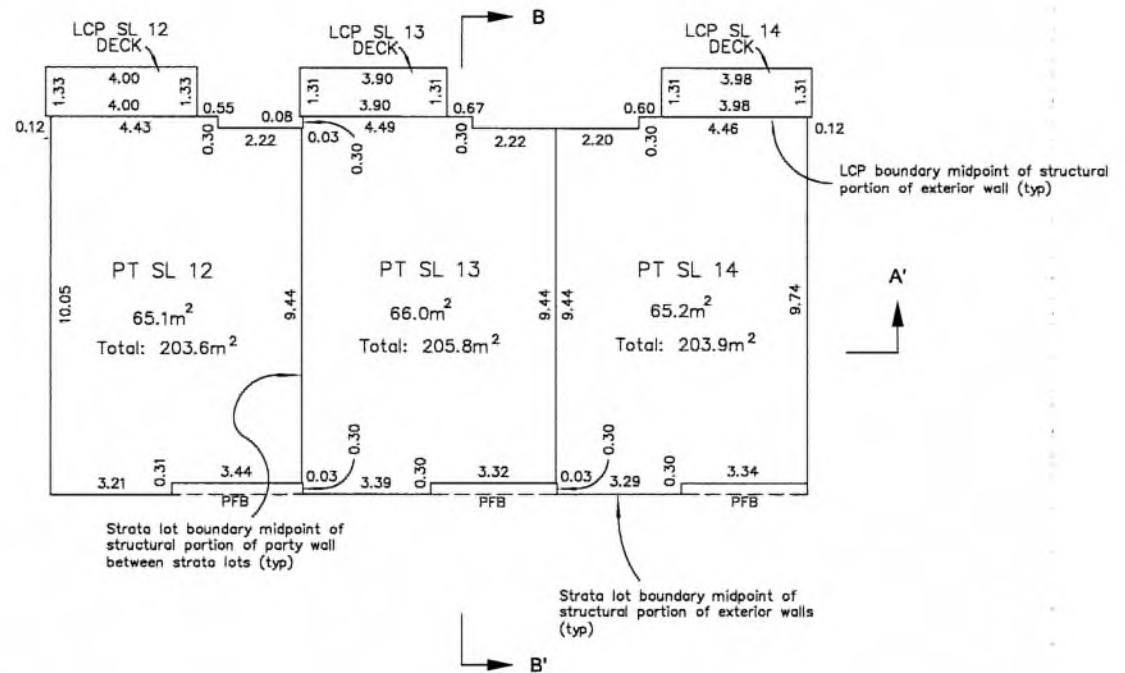

RUNNALLS DENBY

british columbia land surveyors

259A Lawrence Avenue
Kelowna, B.C.
V1Y 6L2

Phone: (250)763-7322
Email: jen@runnallsdenby.com

DWG. No.: 16488 Strata

FILE: 16488

Jennifer Ashton, BCLS 984
November 30, 2023

BUILDING 4 LEVEL 3

Sheet 20 of 22 Sheets

STRATA PLAN EPS9966 PHASE 1



The intended plot size of this plan is 432mm in width by 280mm in height (B size) when plotted at a scale of 1:125

(All distances are in metres)

LEGEND

- SL Denotes Strata Lot
- NH Denotes Non-Habitable
- LCP Denotes Limited Common Property
- PT Denotes Part of Strata Lot

This sheet shows strata boundary dimensions to the midpoint of the structural portion of the exterior walls and the midpoint between structural portions of party walls between strata lots.

All LCP walkways, decks, driveways and yards are limited in height by the centerline of the floor/ceiling above or its extension.

Cross section arrows on this plan point in the direction of view.

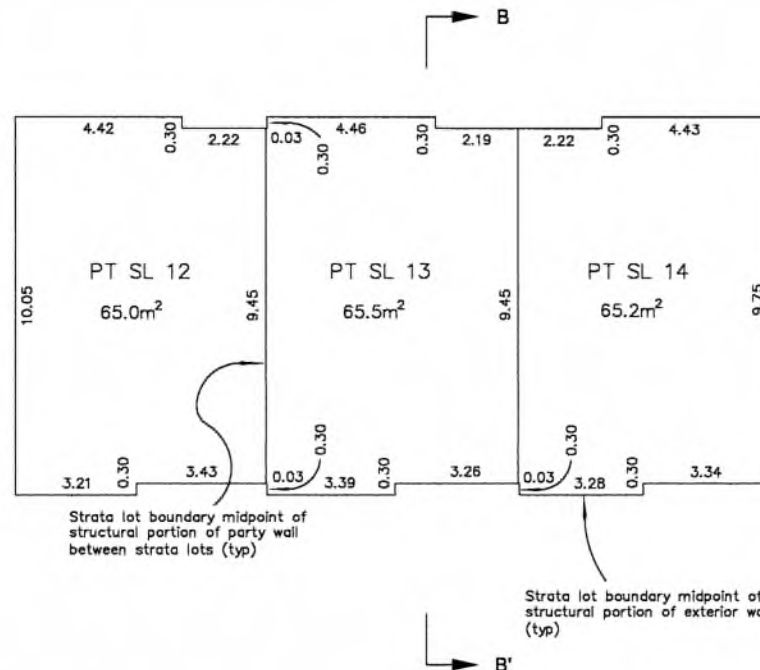
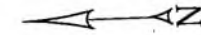

Strata lot boundary midpoint of structural portion of party wall between strata lots (typ)

Strata lot boundary midpoint of structural portion of exterior walls (typ)

RUNNALLS DENBY

british columbia land surveyors

259A Lawrence Avenue
Kelowna, B.C.
V1Y 6L2

Phone: (250)763-7322
Email: jen@runnallsdenby.com

DWG. No.: 16488 Strata

FILE: 16488

Jennifer Ashton, BCLS 984
November 30, 2023

BUILDING 4 LEVEL 4

STRATA PLAN EPS9966 PHASE 1



The intended plot size of this plan is 432mm in width by 280mm in height (B size) when plotted at a scale of 1:125

(All distances are in metres)

LEGEND

- SL Denotes Strata Lot
- NH Denotes Non-Habitable
- LCP Denotes Limited Common Property
- PT Denotes Part of Strata Lot
- PFB Denotes Perimeter of Floor Below

This sheet shows strata boundary dimensions to the midpoint of the structural portion of the exterior walls and the midpoint between structural portions of party walls between strata lots.

All LCP walkways, decks, driveways and yards are limited in height by the centerline of the floor/ceiling above or its extension.

Cross section arrows on this plan point in the direction of view.

All LCP Patios, Decks, Driveways and Terraces are limited in height by the center of the floor above, or its extensions, or where there is no floor above, by the average height of a Strata Lot in the same building, unless otherwise indicated.

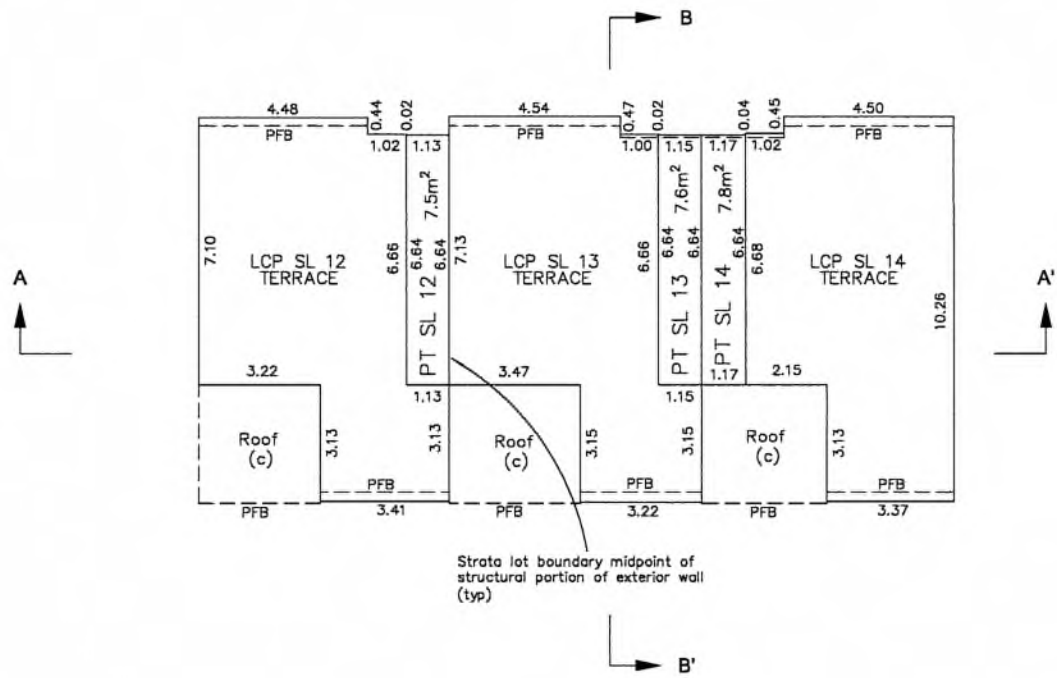

RUNNALLS DENBY

british columbia land surveyors

259A Lawrence Avenue
Kelowna, B.C.
V1Y 6L2

Phone: (250)763-7322
Email: jen@runnallsdenby.com

BUILDING 4 CROSS SECTION

STRATA PLAN EPS9966 PHASE 1



The intended plot size of this plan is 432mm in width by 280mm in height (B size) when plotted at a scale of 1:150
(All distances are in metres)

LEGEND

- SL Denotes Strata Lot
- LCP Denotes Limited Common Property
- PT Denotes Part of Strata Lot
- NH Denotes Non-Habitable

This sheet shows strata boundary dimensions to the midpoint of the structural portion of the exterior walls and the midpoint between structural portions of party walls between strata lots.

CROSS SECTION A-A'

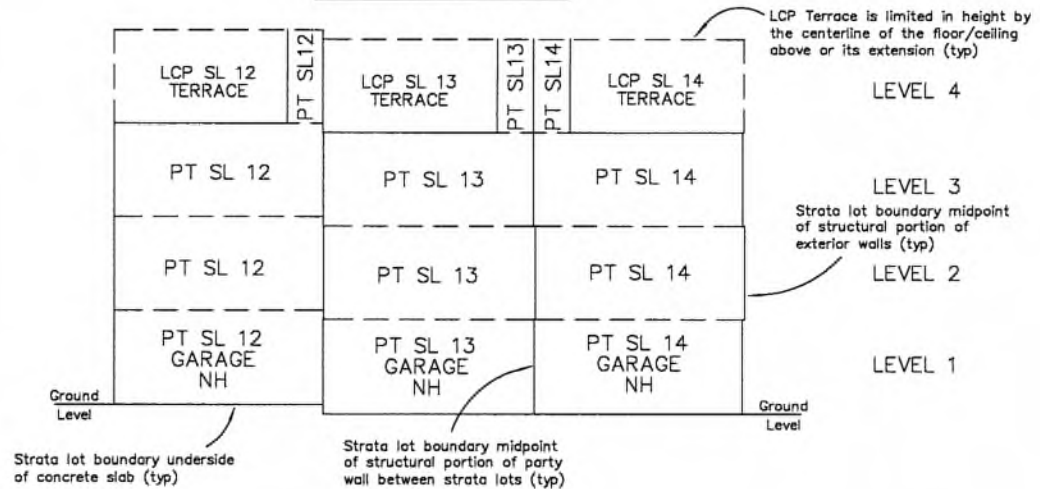

CROSS SECTION B-B'

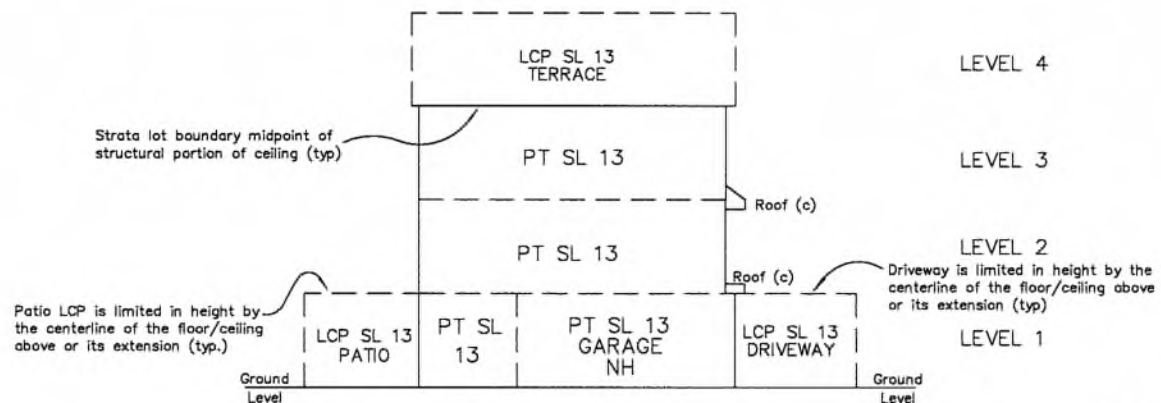

RUNNALLS DENBY
british columbia land surveyors

259A Lawrence Avenue
Kelowna, B.C.
V1Y 6L2

Phone: (250)763-7322
Email: jen@runnallsdenby.com

DWG. No.: 16488 Strata

FILE: 16488

Jennifer Ashton, BCLS 984
November 30, 2023